

SPN-42 Series

dp Transmitter / Instrumentation

2 Line Surge Suppressor



Features:

- ▶ Compatible with all models of dp field transmitters and 420 mA measurement and process control instruments.
- ▶ Simple screw-in mounting using a standard 1/2 inch conduit.
- ▶ Convenient, secure screw clamp ground terminal or floating ground wire.
- ▶ Exceeds severity level 4 of IEC/EN 61000-4-4 (Provides 2.5 kA/line of surge protection).
- ▶ Unique multi-stage design provides the most effective suppression available and requires no additional secondary protection.
- ▶ Automatically resets after each transient. No maintenance is required.
- ▶ Space efficient protector is hermetically sealed and suitable for the most hazardous NEMA environments.
- ▶ The SPN-42 Series can be used on analog and digital signal/data lines.
- ▶ Sub nanosecond response time stops failures due to lightning, spikes and over-voltage surges while minimizing other electrical noise.
- ▶ Superior protection at an affordable price.

Applications:

The SPN-42 Series is designed to protect 2 wire transmitters, measurement and process control equipment, and 4-20 mA loop instrumentation. This Series may be used on analog or digital signal/data lines.

The SPN-420 Series is a dual-ended enclosure with external ground lug. The SPN-420S is a single-ended enclosure with an external ground lug. The SPN-42F is a dual-ended enclosure with floating ground wire. The SPN-42FS is a single-ended enclosure with floating ground wire.

Select the model according to the operating voltage found on the reverse side of this data sheet.

Select the 12VDC model for RS-422 or RS-485 and the 24VDC model for RS-232C applications.

Typical Installation:

The SPN-42 Series pipe style mounting allows direct screw-in to all dp transmitters and other process measurement instrumentation. Mount the suppressor as near the equipment it is to protect as possible. A separate earth ground is not required if the instrument/conduit housing is properly grounded. Use #12 AWG or larger if a ground wire is needed.

SURGE CONTROL®
A PRODUCT OF CCI

SPN-42 Series Operating Specifications:

Specifications	SPN-42XX05	SPN-42XX14	SPN-42XX25	SPN-42XX28	SPN-42XX36	SPN-42XX50	SPN-42XX60
"RS" Applications	N/A	RS-422 RS-485	RS-232	N/A	N/A	N/A	N/A
Operating Voltage	5 Volts	12 Volts	24 Volts	28 Volts	36 Volts	50 Volts	60 Volts
Maximum Operating Voltage	6 Volts	14 Volts	27 Volts	30 Volts	38 Volts	55 Volts	67 Volts
Maximum Operating Current	200 mA	200 mA	200 mA	200 mA	200 mA	200 mA	200 mA
Clamping Action Turn-On	7.1 Volts	14.3 Volts	28.5 Volts	31.4 Volts	40.9 Volts	58.9 Volts	71.3 Volts
Maximum Clamping at 2 kA (8 x 20 µSec)	11 Volts	22 Volts	44 Volts	46 Volts	58 Volts	81 Volts	94 Volts
Maximum Surge Voltage	20 kV	20 kV	20 kV	20 kV	20 kV	20 kV	20 kV
Maximum Surge Current (8 x 20 µSec)	2.5 kA	2.5 kA	2.5 kA	2.5 kA	2.5 kA	2.5 kA	2.5 kA
Maximum Current Leakage/Line at Operating Voltage	500 µA	5 µA	5 µA	5 µA	5 µA	5 µA	5 µA
Maximum Capacitance/Line at Operating Voltage	4000 pF	2000 pF	500 pF	500 pF	400 pF	300 pF	200 pF
Response Time	Less than 1 nanosecond						
Operating and Storage Temperature	-40 Degrees Celsius to +85 Degrees Celsius						

Consult the factory for other applications and operating conditions and specifications. All specifications at 25 degrees Celsius.

Part Numbering:

SPN-42 XX

Operating Voltage:

See Table Above

Mounting Option:

- F – dual-ended
- FS – singled-ended
- 0 – dual-ended, external ground lug
- 0S – singled-ended, external ground lug

Typical Installation:

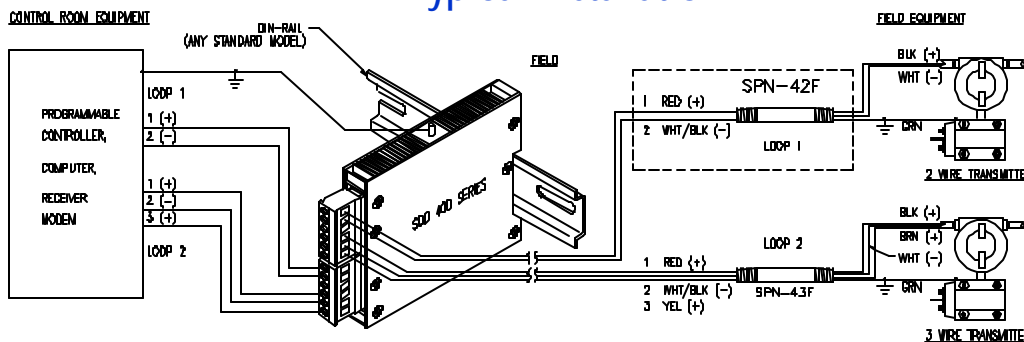

Outline Dimensions:

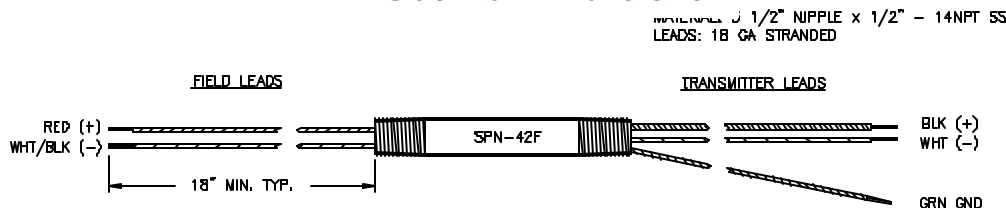

Circuit Components, Inc.
 2400 S. Roosevelt Street Tempe, AZ - 85282
 Tel: 480-967-0624 - Fax: 480-967-9385
 Email: info@surgecontrol.com - Website: www.surgecontrol.com

SURGE CONTROL®
 A PRODUCT OF CCI

This information is not intended to and does not create any warranties, expressed or implied, including any warranty of merchantability or fitness for a particular purpose. Circuit Components Inc. reserves the right to change specifications at any time without notice.