

SDD-DHP

Data Highway Plus
DIN Rail Mount

Surge Suppressor

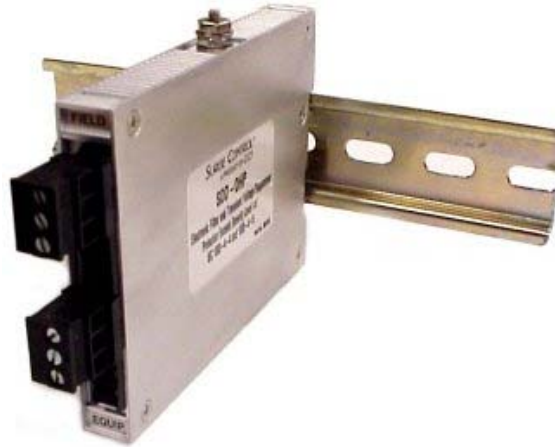

Features:

- ▶ Vertical universal mounting on any standard DIN-Rail.
- ▶ Fast, direct wire termination to 6-position plug-in screw connector.
- ▶ Sub nanosecond response time stops failures due to lightning, spikes and over-voltage surges while minimizing other electrical noise.
- ▶ Two grounding options: DIN-Rail foot to grounded rail or screw post.
- ▶ Unique multi-stage design provides the most effective suppression available and requires no additional secondary protection.
- ▶ Automatically resets after each transient. No maintenance is required.
- ▶ Exceeds severity level 4 of IEC/EN 61000-4-4 (Provides 2.5 kA/line of surge protection).
- ▶ Space efficient protector is hermetically sealed and suitable for the most harsh environments

Applications:

The SDD-DHP is designed to protect programmable controllers, computers and other devices that communicate through control networks such as an Allen Bradley DHP local area network or the Remote I/O. The SDD-DHP can be used for all shielded twin-axial cable (Blue Hose) control networks.

Select the SDP-120 Series for DIN-Rail 120VAC line protection.

Select the SDD-DN DIN-Rail mount suppressor for DeviceNet applications.

Select the SDD-DH485 DIN-Rail mount suppressor for DH-485 applications.

Panel-mount versions of all models are also available.

Typical Installation:

Mount the SDD-DHP suppressor on any standard DIN-Rail. Connect clear, drain, and blue wires from twin-ax cable to the suppressor as indicated on the back of this sheet. Connect the protected lines to the equipment and dress away from the incoming field lines. The suppressor must be connected to a good earth ground. Keep the ground wire (#12 AWG or larger) short and place the suppressor as near to the equipment it is to protect as possible. Equipment ground and suppressor ground should be common.

SURGE CONTROL®
A PRODUCT OF CCI

SDD-DHP Operating Specifications:

Specifications	Lines 1 and 2	Shield
Operating Voltage	12 Volts	N/A
Maximum Operation Voltage	14 Volts	N/A
Maximum Operating Current	200 mA	N/A
Clamping Action Turn-On	14.3 Volts	6.4 Volts
Maximum Clamping at 2 kA (8 x 20 mSec)	22 Volts	10 volts
Current Leakage/Line At Operating Voltage	10 μ A max	500 μ A max
DC Series Resistance per Line	2.7 Ohms	N/A
Maximum Surge Voltage	20 kV	
Maximum Surge Current (8 x 20 mSec)	3 kA	
Capacitance per Line	100 pF max	
Response Time	Less than 1 nanosecond	
Operating and Storage Temperature	-40 Degrees Celsius to +85 Degrees Celsius	

Note: Consult the factory for other applications and operating conditions and specifications. All specifications at 25 degrees Celsius.

Typical Installation:

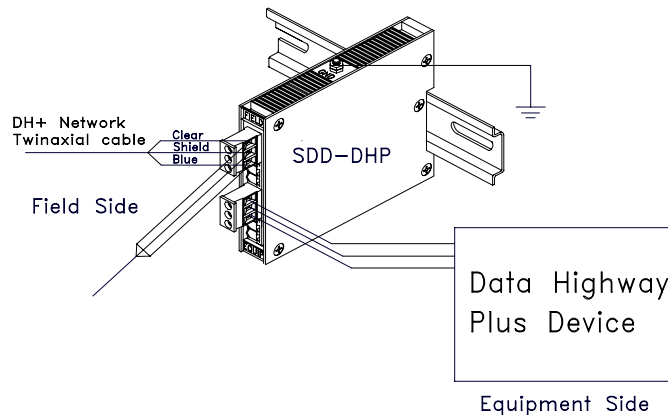

Outline Dimensions:

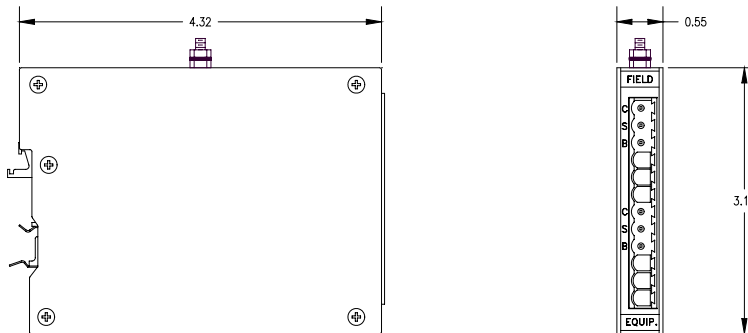

Circuit Components, Inc.
 2400 S. Roosevelt Street Tempe, AZ • 85282
 Tel: 480-967-0624 • Fax: 480-967-9385
 Email: info@surgecontrol.com • Website: www.surgecontrol.com

SURGE CONTROL®
 A PRODUCT OF CCI

This information is not intended to and does not create any warranties, expressed or implied, including any warranty of merchantability or fitness for a particular purpose. Circuit Components Inc. reserves the right to change specifications at any time without notice.